

MACHINERY MOUNT SERIES: 297 SERIES

Dimensions & Performance Characteristics

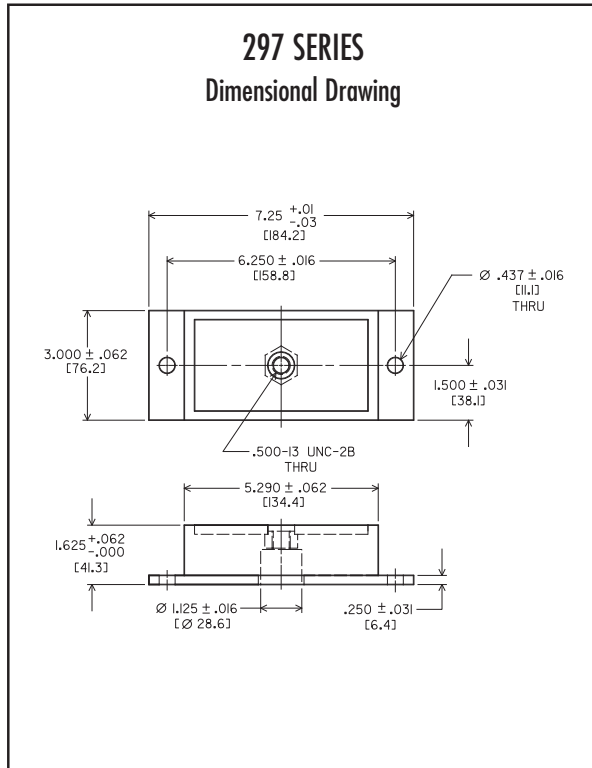

297 SERIES LOAD RANGE DATA	
Part #	Maximum Static Load/Isolator (lbs.)
297-15	1,500
297-20	2,000
297-30	3,000
297-44	4,400

